

# GTEM-Cells acc. to IEC/EN 61000-4-20

Septum-height: 250 mm to 2000 mm / 0.1 MHz to 18 GHz



## Description

The GTEM-cell is a TEM waveguide with the upper frequency limit extended to the GHz range. It is a low-cost alternative measurement facility for both radiated emission and immunity measurements. It is included in the published standard IEC/EN 61000-4-20 "Emission and Immunity Testing in Transverse Electromagnetic (TEM) Waveguides". Compared to other measuring methods like EMC test in anechoic chambers or OATS (Open Area Test Sites), GTEM-cells offer some significant advantages for the testing of small and medium sized EUT's (Equipment

Under Test) up to a frequency range of 18 GHz. Quick turnarounds of the EUT as well as numerous testing variations are easy and fast to handle. Switching from emission to immunity testing requires only simple adjustments from receiver input to amplifier output. You are irrespective of long waiting times associated with off-site test labs or weather and ambient delays that can occur at OATS facilities. Whether you are at the design qualification, pre-compliance, compliance, or production sampling stage, the GTEM is the right choice for you.

### Calculation of the required forward power for radiated immunity tests:

$$P = (E \times h)^2 / R \times \text{flatness factor (2)} \times \text{modulation factor (3.24 for 80 \%AM)}$$

E= required field strength; h=septum height in meter; R= input impedance 50 Ω

### Example:

Field strength 10 V/m, 80 %AM with GTEM 1000:

$$P = (10 \times 1.0 \text{ m})^2 / 50 \times 2 \times 3.24 = 12.96 \text{ W}$$

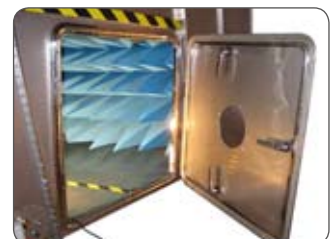

# GTEM-Cells acc. to IEC/EN 61000-4-20

Technical specifications	250	400	500	750	1000
<b>Electrical Data</b>					
Input connector	N	N	N	N	N
Nominal impedance	50	50	50	50	50
Frequency range	0.01 MHz-18 GHz*	0.01 MHz-18 GHz*	0.01 MHz-18 GHz*	0.01 MHz-18 GHz*	0.01 MHz-18 GHz*
Typical VSWR	1:1.2	1:1.2	1:1.2	1:1.2	1:1.2
Typical VSWR at critical frequency	≤ 1:1.6	≤ 1:1.6	≤ 1:1.6	≤ 1:1.6	≤ 1:1.6
Max. input power, W continuous*/pulsed	500*/1 Kw	500*/1 Kw	500*/1 Kw	700*/1.5 Kw	700*/1.5 Kw
<b>Electrical Equipment / Options</b>					
Mains connectors	Fix/CEE	Fix/CEE	Fix/CEE	Fix/CEE	Fix/CEE
Input socket plug 10Aac	●	-	-	-	-
Input socket plug 16Aac	○	●	●	●	●
Output socket tape 16Aac	○	●	●	●	●
Additional sockets for EUT	○	○	○	○	○
Ground connection M6	●	●	●	●	●
AC filter 6 A / 3 wires	●	○	○	○	○
AC filter 10 A / 3 wires	○	●	●	●	●
AC filter 16 A / 5 wires	○	○	○	○	○
AC filter 30 A / 5 wires	○	○	○	○	○
AC filter 64 A / 5 wires	○	○	○	○	○
Electrical safety interlock	○	○	○	○	○
Indoor lighting 50 W	○	○	○	○	○
9-poles signal filter (DB9)	○	○	○	○	○
25-poles signal filter (DB25)	○	○	○	○	○
Channel for fibre optic leads (3 couple)	●	●	●	●	●
RF feed-thru connectors N Type	1	1	1	1	1
RF feed-thru connectors SMA Type	2	2	2	2	2
<b>Mechanical Equipment / Options</b>					
Second small door close to input	-	-	-	○	○
Window in door, 20 cm Ø	○	○	○	○	○
Gas / Water feed-thru plates	○	○	○	○	○
Honeycomb panel	○	○	○	○	○
Fans N.4 12x12 cm	-	○	○	○	○
Empty technical panels	-	-	1	3	3
<b>Mechanical Dimensions / Max. EUT size</b>					
Outer (LxWxH), cm	115x64x44	220x122x83	300x168x115	400x220x150	500x271x188
Door (WxH), cm	30x23	40x40	40x40	61x61	80x90**
Wheeled undercarriage	-	○	●	●	●
Weight kg approx.	24	60	200	400	600
Max. test volume (LxWxH), cm	20x20x15	35x40x25	40x40x30	60x60x50	75x75x70
Defined test vol. ± 3 dB < 1000 MHz (LxWxH), cm	15x15x10	25x30x13	30x35x17	45x45x25	60x60x30
Septum height	250 mm	400 mm	500 mm	750 mm	1000 mm

\*\* Other sizes are available on request

\*6 GHz standard, 18 GHz optional

● Standard

○ Costed option

- Not provided

# GTEM-Cells acc. to IEC/EN 61000-4-20

Technical specifications	1250	1500	1750	2000
<b>Electrical Data</b>				
Input connector	N	N	N	N
Nominal impedance	50	50	50	50
Frequency range	0.01 MHz-18 GHz*	0.01 MHz-18 GHz*	0.01 MHz-18 GHz*	0.01 MHz-18 GHz*
Typical VSWR	1:1.2	1:1.2	1:1.2	1:1.2
Typical VSWR at critical frequency	≤ 1:1.6	≤ 1:1.6	≤ 1:1.6	≤ 1:1.6
Max. input power, W continuous/pulsed*	500/1000*	600/1200*	800/1400*	1000/1600*
<b>Electrical Equipment / Options</b>				
Mains connectors	Fix/CEE	Fix/CEE	Fix/CEE	Fix/CEE
Input socket plug 16Aac	●	●	●	●
Output socket tape 16Aac	●	●	●	●
Additional sockets for EUT	○	○	○	○
Ground connection M6	●	●	●	●
AC filter 10 A / 3 wires	●	●	●	●
AC filter 16 A / 5 wires	○	○	○	○
AC filter 30 A / 5 wires	○	○	○	○
AC filter 64 A / 5 wires	○	○	○	○
Electrical safety interlock	○	○	○	○
Indoor lighting 50W	○	○	○	○
9-pole signal filter (DB9)	○	○	○	○
25-pole signal filter (DB25)	○	○	○	○
Channels for fibre optic leads (3 couple)	●	●	●	●
RF feed-thru connectors N Type	1	1	1	1
RF feed-thru connectors SMA Type	2	2	2	2
<b>Mechanical Equipment / Options</b>				
Second small door close to input	○	○	○	○
Window in door, 20 cm Ø	-	○	○	○
Gas / Water feed-thru plates	○	○	○	○
Honeycomb panel	○	○	○	○
Fans N.4 12x12 cm	○	○	○	○
Empty technical panels	-	1	3	3
High power termination	○	○	○	○
<b>Mechanical Dimensions / Max. EUT size</b>				
Outer (LxWxH), cm	600x306x252	700x358x255	800x410x290	900x462x324
Door (WxH), cm	80x110**	80x120**	80x130**	80x140**
Wheeled undercarriage	●	●	●	●
Weight kg approx.	850	1000	1300	1650
Max. test volume (LxWxH), cm	95x95x85	120x120x100	140x140x60	175x175x70
Defined test vol. ± 3 dB < 1000 MHz, LxWxH, cm	75x75x42	100x100x50	125x125x58	150x150x65
Septum height	1250 mm	1500 mm	1750 mm	2000 mm

\*\* Other sizes are available on request

\*6 GHz standard, 18 GHz optional

● Standard

○ Costed option

- Not provided

# GTEM test set-up for radiated immunity tests and emission measurements:

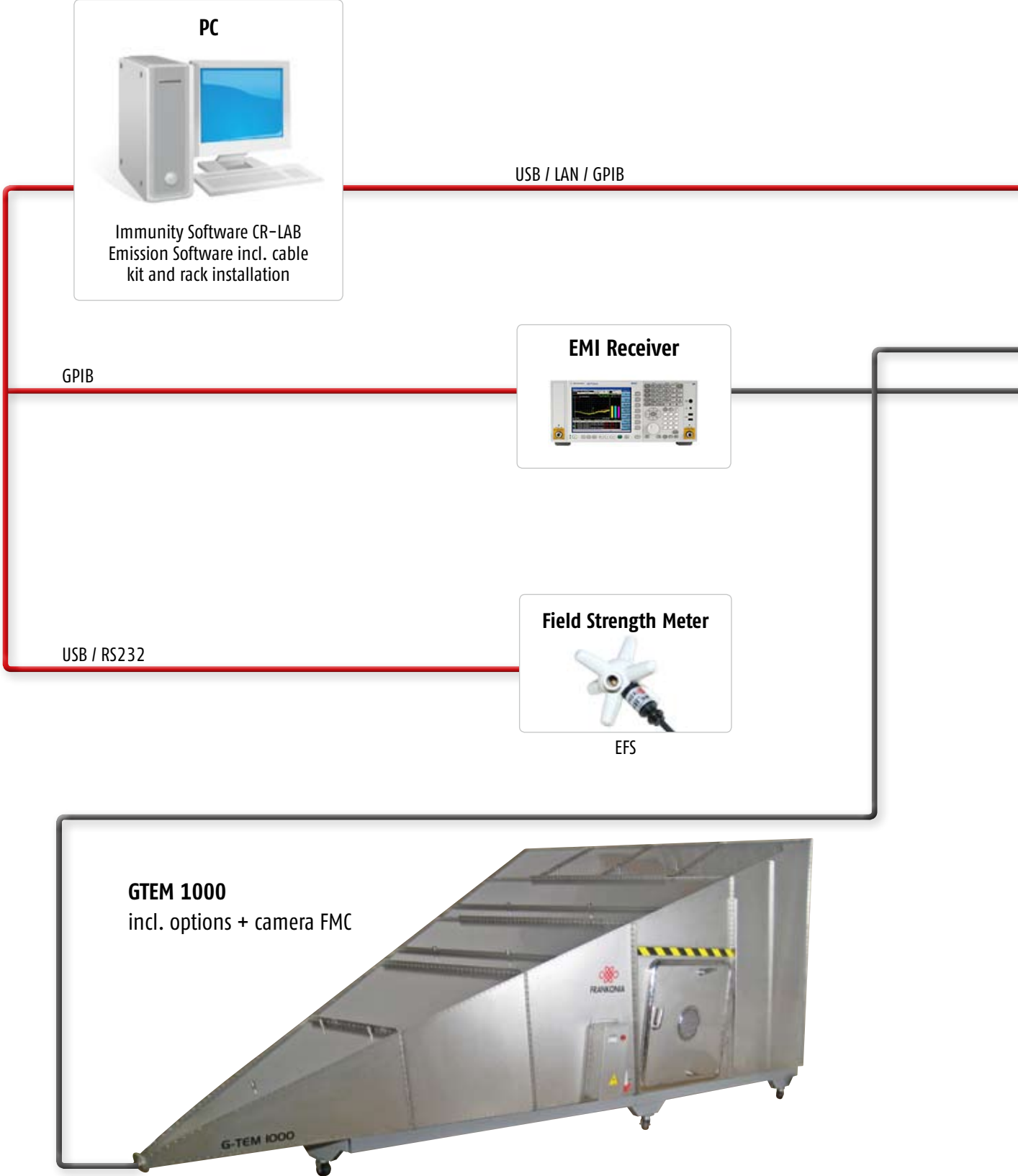

# GTEM test set-up for radiated immunity tests and emission measurements:

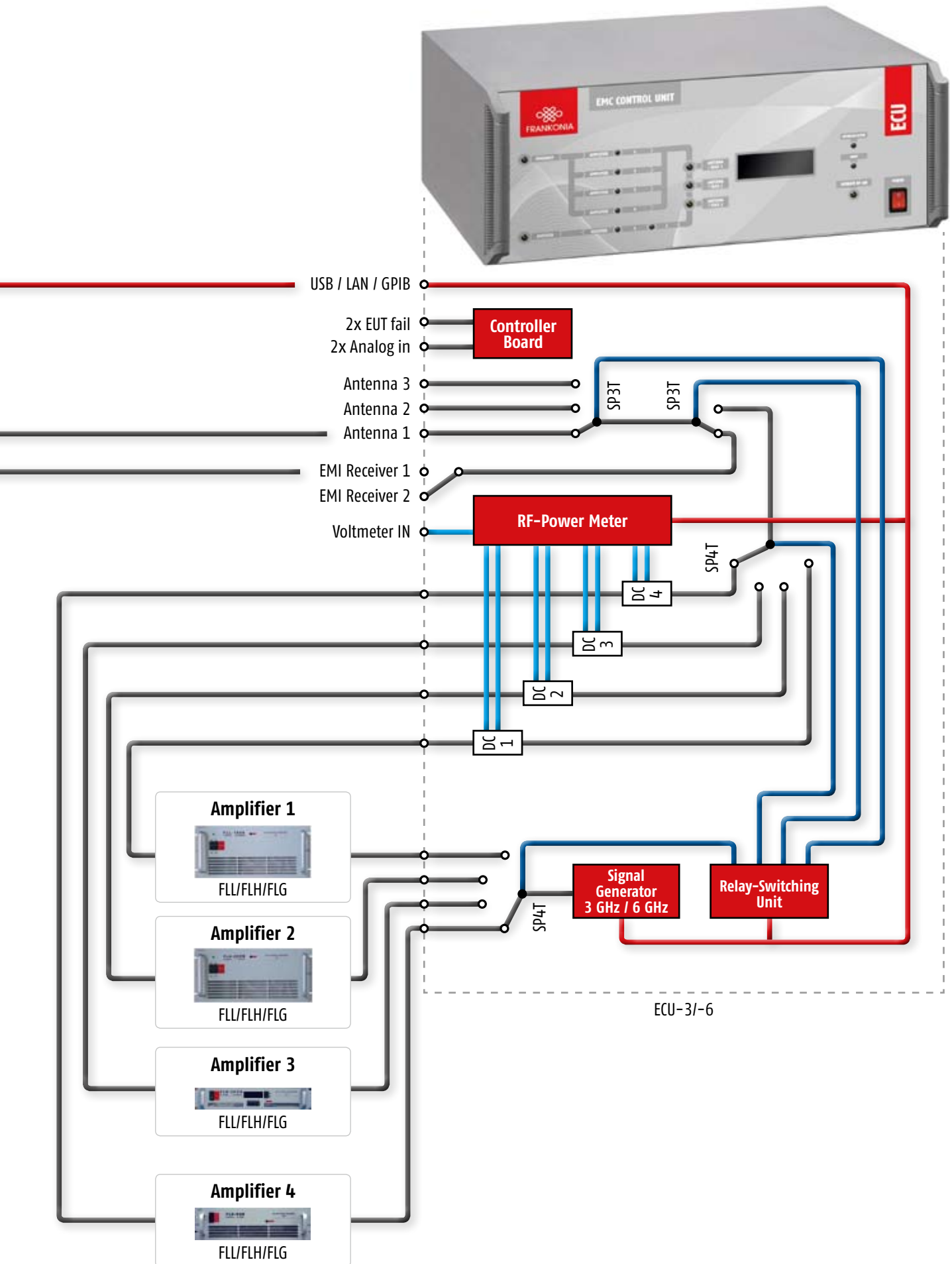

# GTEM-Cells acc. to IEC/EN 61000-4-20

Type	I/O ports	GTEMs MODEL	
		250-400	500-750-1000-1250 1500-1750-2000
GTEM-B01	EIA 7/8" Flange input connector (up to 3 GHz)	○	○
GTEM-B02	7/16" Input connector (up to 3 GHz)	○	○
GTEM-B03	1 Kw max. input power, (up to 3 GHz) (the max. input power is limited by the spec. of the max input power of the selected GTEM)	○	-
GTEM-B04	Upgrade input power 1.6 Kw, (up to 3 GHz) (the max. input power is limited by the spec. of the max input power of the selected GTEM)	-	○
GTEM-B05	Channels for fibre optical feed-thru (additional 3 pairs)	○	○
GTEM-B06	Additional RF feed-thru connectors N type	○	○
GTEM-B07	Additional RF feed-thru connectors SMA type	○	○
<b>Electrical Equipment / Options</b>			
GTEM-B08	Additional socket for EUT	○	○
GTEM-B09	Internal illumination (halogene, 50 W)	○	○
GTEM-B10	AC filter 16 A / 5 wires	○	○
GTEM-B11	AC filter 30 A / 5 wires	-	○
GTEM-B12	AC filter 64 A / 5 wires	-	○
GTEM-B13	Electrical safety interlock	○	○
GTEM-B25	9-pole DB9 signal EMI filter	○	○
GTEM-B14	25-pole DB25 signal EMI filter	○	○
GTEM-B26	RJ11 (RJ9) feed-thru connector	○	○
GTEM-B32	RJ45 feed-thru connector	○	○
<b>Mechanical Equipment / Options</b>			
GTEM-B15	Second door close to input	-	○
GTEM-B16	Window in door, Ø 200 mm	○	○
GTEM-B17	Gas / water-feed-thru plates	○	○
GTEM-B18	Honeycomb panel	-	○
GTEM-B19	Fan kit for GTEM on technical panel	-	○
GTEM-B20	Door for tests acc. to SAE J1752/3	○	○
GTEM-B21	Wheeled undercarriage	○	●
GTEM-B23	Vertical positioning, turn of door position, plastic table over pyramids	○	-
GTEM-B27	Empty installation panel, Ø 200 mm	○	●
GTEM-B28	Fan kit incl. channel for heat sink	○	○

● Standard      ○ Costed option      - Not provided